

# HydroWatch MP

**MAINS-PRESSURE AUTOMATIC TOPUP,  
PRESSURISATION AND MONITORING UNIT**



0800 77 78 79 | [office@flowquip.co.nz](mailto:office@flowquip.co.nz)

We supply components that make it easy for engineers and tradesmen to create and maintain piped systems.

**FlowQuip**  
Piped Equipment Specialties

# HydroWatch MP

## Mains-Pressure Automatic Pressurisation and Monitoring Unit

HydroWatch MP is an electronically controlled, pumpless pressurisation unit for sealed heating, chilled-water and condenser-water systems. It uses the incoming mains cold-water supply to fill, pressurise and continuously maintain the system, replacing the traditional combination of an RPZ valve, fill loop and pressure switch with a single integrated unit.

Unlike conventional pressurisation kit, HydroWatch MP measures every litre it delivers. It reports the system's average daily water loss, calculates the volume of inhibitor required for correct dilution, and gives the building manager actionable data on system integrity — not just an alarm contact when something has already gone wrong.



## A different class of pressurisation unit

**It measures, it doesn't just maintain.** Every fill is metered. The initial system volume is captured during commissioning, and the average daily water loss is calculated and displayed in litres per day. Slow leaks, weeping joints and failing seals show up as a trend on the controller and over MODBUS, long before they become a callout.

**It calculates the inhibitor dose for you.** Once the system has been filled and pressurised, HydroWatch MP displays the volume of inhibitor required for correct dilution based on the measured fill. The figure updates as further water is added, so the right top-up dose is always available at service. No spreadsheets, no guesswork, no over- or under-dosing.

**It sees both sides of the air break.** Two electronic pressure sensors monitor the incoming mains and the sealed system independently. If mains pressure falls below the minimum required to deliver the system set point, the fill cycle is

delayed and the condition is reported on screen rather than running unproductively against an inadequate supply. On fluctuating mains, the unit enters a reduced-capability "limp" mode and continues to protect the system until normal supply pressure returns.

**It commissions itself.** The installer enters six items — system type, kW rating, static head, PRV rating, expansion-tank volume and pre-charge. HydroWatch MP calculates and sets every operating set point, alarm threshold, and timer automatically. Every value remains accessible and can be manually overridden via a protected editing mode.

**It fills the system without a bypass.** The initial fill is performed through the unit, with accurate flow rate and volume measurement throughout. One less temporary connection on site, and a permanent record of the fill volume from which every subsequent calculation is derived.

## Features

- Pumpless operation; powered by incoming mains pressure 1.5 – 9.0 bar
- Twin electronic pressure sensors — mains supply and circulating system
- Accurate fill-volume and fill-rate measurement; no bypass hose required
- Automatic system-inhibitor dose calculation
- Average daily water-loss reporting (litres per day)
- Self-commissioning controller with on-screen guided set-up
- Manual override of all set points via protected editing mode
- “Limp” mode for fluctuating mains supplies
- 24-hour fill timeout, resettable from the front panel
- Backlit LCD display with four-button keypad and multi-colour status LEDs
- Fault history (most recent three events), pump run-hours and mains-voltage logging
- Three volt-free dry-contact relays — high pressure, low pressure, general alarm — selectable NO or NC
- MODBUS RTU over RS485 for full Building Management System integration
- 24 V DC solenoid feed valves — no mains-voltage exposure on the wet side
- Serviceable in-line mesh filter on the inlet
- Physical air break in the water feed — Fluid Category 5 backflow protection
- 230 V supply via 1.5 m flex with fused plug
- Compact wall-mounted chassis; 15 mm BSP inlet and outlet, 3/4” BSP tundish drain

## How it operates

At power-up, the controller guides the installer through six numeric entries: system type, system kW rating, static head, PRV rating, expansion-tank volume and pre-charge pressure. Each entry is validated, and the operating set points are then calculated and displayed for confirmation.

The unit performs the initial fill through its own solenoid valves, displaying fill rate (l/min) and accumulated volume in real time. On reaching the calculated cut-out pressure, the unit displays the inhibitor volume to be dosed.

In normal operation the LCD displays:

- System pressure
- Average water loss (litres per day)
- Total volume added since the counter was last

reset

- Current status

Further screens show fill rate during a cycle, all pump-on / pump-off / LP / HP set points, system type, static head, kW rating, pump run-hours, mains voltage and the three most recent faults logged. The same data is available remotely over MODBUS RTU, in parallel with the three volt-free alarm relays.

Minor pressure losses — typically due to small leaks, air venting or service work — trigger a measured re-pressurisation cycle. Significant losses raise the appropriate alarm. The 24-hour fill timeout halts a cycle that fails to reach pressure (for example, during a major leak) and is reset with a single button press once the underlying problem has been addressed.

## Backflow Compliance

The water feed incorporates a physical air break to provide Fluid Category 5 backflow protection in accordance with the Water Supply (Water Fittings) Regulations 1999 and BS EN 1717. The unit is designed to replace RPZ-valve-based filling arrangements on sealed systems. WRAS approval is in progress.

Non-return valves, pressure-reducing valves and RPZ valves must not be installed between HydroWatch MP and the system; HydroWatch MP must feed the system upstream of the circulating pump suction.

## Specifications

	HydroWatch MP
Operating principle	Mains-pressure, pumpless
Mains supply pressure	1.5 – 9.0 bar
range System fill pressure	To within 0.3 bar of available mains pressure
Inlet / outlet connections	15 mm BSP, isolating valves fitted
Inlet filter	Serviceable in-line mesh
Tundish drain	3/4" BSP
Power supply	230 V / 50 Hz, 1.5 m flex with fused plug
Control valves	24 V DC solenoid
Pressure sensors	2 × electronic (mains and system)
Display	Backlit LCD, 4-button keypad, multi-colour status LEDs
Volt-free outputs	3 × dry contact (HP, LP, General) — selectable NO/NC, 24 V / 1 A resistive
BMS interface	MODBUS RTU over RS485 (8 data, no parity, 1 stop)
Fill timeout	24 hours, resettable
Mounting	Vertical wall-mount; 5 × self-tapping fixings supplied
Clearances	600 mm front, 150 mm each side, 1000 mm above
Backflow protection	Physical air break — Fluid Category 5 (BS EN 1717 / Water Supply (Water Fittings) Regulations 1999) WRAS approval in progress
Approvals	
Shipping Weight	8kg

## Selection Guide

Levels above unit	Static height (m)	Min. mains pressure (bar)	Feed cut-in / cut-out (bar)	LP / HP alarm (bar)	Expansion-tank pre-charge (bar)	PRV setting (bar)
1	0		1.0 / 1.3	0.8 / 2.3	1	3
2	4	1.6	1.4 / 1.7	1.1 / 2.7	1.4	3
3	8	2	1.8 / 2.1	1.5 / 3.1	1.8	4
4	12	2.4	2.2 / 2.5	1.9 / 3.5	2.2	4
5	16	2.8	2.6 / 2.9	2.3 / 4.1	2.6	5
6	20	3.2	3.0 / 3.3	2.7 / 4.5	3	5
		3.6				

Sized to deliver a minimum 0.8 bar static pressure at the highest point of the system. Allow 1.0 bar base static, plus 0.4 bar per level ( $\approx 3.5\text{--}4$  m) above the unit. Where the available mains pressure is below the minimum required for the building's static head, specify the break-tank-and-pump model, HydroWatch BT.

## Installation

HydroWatchMP is wall-mounted, vertical, with all water and drain connections at the base. Inlet, outlet and tundish are sized for 15 mm BSP, 15 mm BSP and ¾" BSP respectively. The outlet must tee into the system return before the suction side of the circulating pump. The tundish drain must be piped to a suitable foul drain with continuous fall.

The unit is supplied with isolating valves fitted to the inlet and outlet, an in-line serviceable mesh filter, a 1.5 m fused mains lead, five self-tapping wall fixings, and installation documentation.

Required clearances: 600 mm to the front, 150 mm to each side and 1000 mm above.

Installation environment: indoor, dry, above 4 °C, away from direct sunlight, moisture and corrosive substances.

## Installation Example

Typical connection to closed expansion system

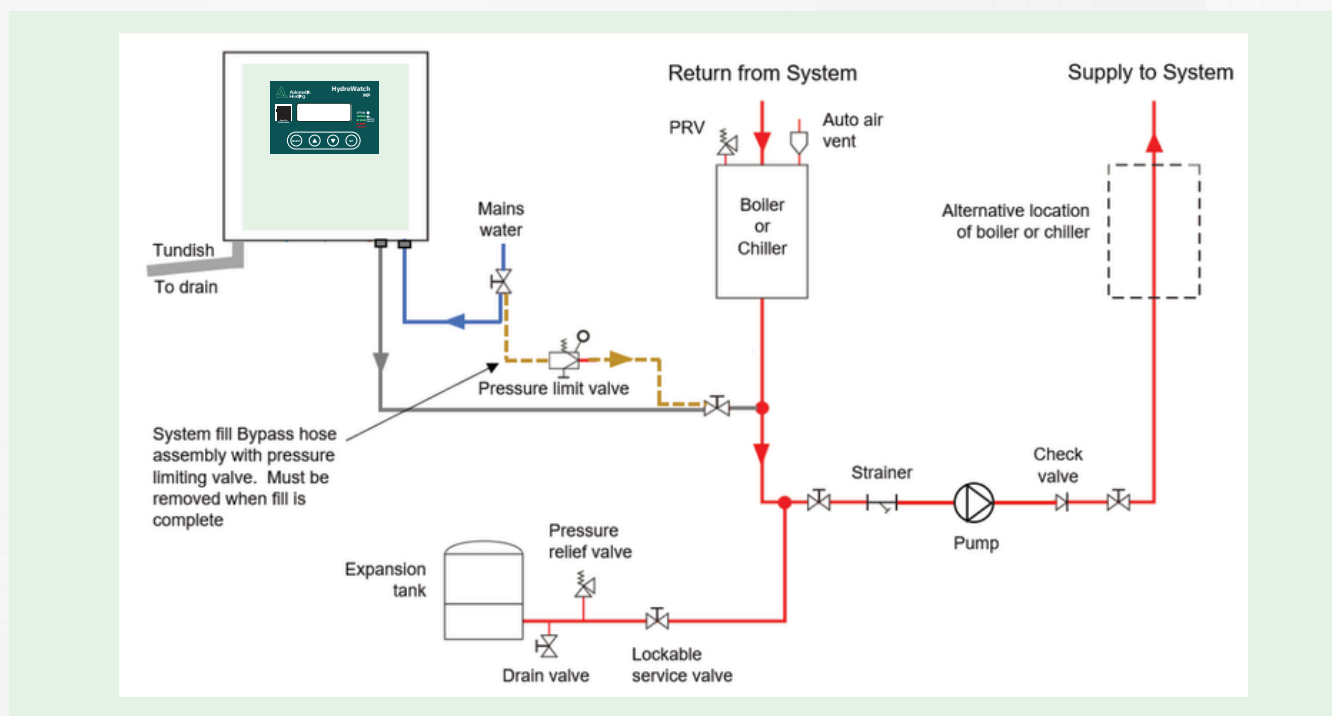

## The HydroWatch range

**HydroWatch MP**—mains-pressure, pumpless. For sealed systems where mains pressure is adequate to deliver the required static pressure at the highest fixture.

**HydroWatch BT** — break-tank with pressurising pump. For installations where mains pressure is insufficient or where Type AB physical separation via a break tank is preferred. Shares the HydroWatch controller, monitoring and reporting platform.

## Dimensional Data



PLAN VIEW

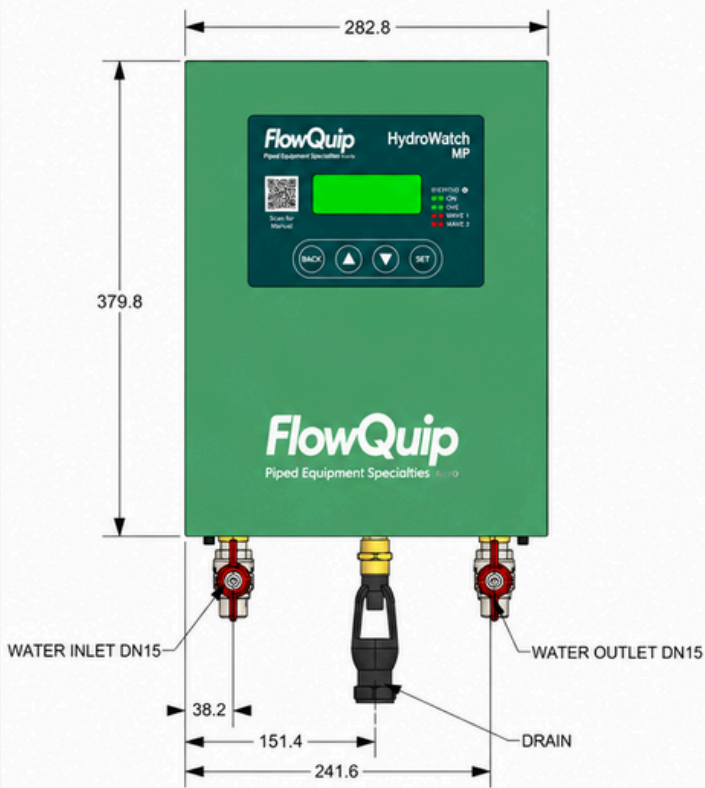

FRONT VIEW



RIGHT SIDE VIEW



ISO VIEWS